



HEAVY DUTY BILGE PUMP

4730, 4740, 4760 & 4770

INSTALLATION INSTRUCTIONS

05/10

69424 Rev. A

FEATURES:

Attwood Heavy Duty Bilge Pumps are the newest development in high output pumps. All models have a removable strainer basket for simple installation and easy cleaning. There are two ways to configure your Heavy Duty Bilge Pump - Automatic Operation or Manual Operation. The bilge pump system can be converted to fully-automatic operation by installing the S3 Electronic Bilge Switch (part no. 4801 or 4802).

AUTOMATIC OPERATION

All boats over 20' (6.1 m) in length which have sleeping accommodations (excluding fold-out cockpit seats) require automatic bilge pump systems. For fully-automatic operation, follow the AUTOMATIC ELECTRONIC SWITCH INSTALLATION and AUTOMATIC OPERATION WIRING instructions.

MANUAL OPERATION

For manual operation of your bilge pump system, disregard the references to Automatic Switch Installation and operation. Check the chart below to select the proper pump, fuse size, and thru-hull connector for your boat application.

Part Number	Model	Volts	Amp Fuse	Outlet Hose Inside Dia.	Thru-Hull Connector
4730	HD 1700	12VDC	10	1-1/8" (29 mm)	3874/67557
4740	HD 1700	24VDC	5	1-1/8" (29 mm)	3874/67557
4760	HD 2000	12VDC	12	1-1/8" (29 mm)	3874/67557
4770	HD 2000	24VDC	12	1-1/8" (29 mm)	3874/67557

Recommendations are based on amount of gallons exhausted per hour (GPH). GPH measurements are typical of production pumps tested using smooth-bore hoses, at 0' head. "Head" refers to the vertical distance between the pump nozzle and the water discharge location. GPH is reduced as head is increased.

The chart below shows gallons and liters per hour ratings for 0' head and 3' (91.4 cm) head. GPH/LPH may also vary depending on power source, hose type, and other variables.

ABYC Specifications 13.6 volts DC (GPH=Gallons Per Hour)	ISO Specifications 12.0 volts DC (LPH=Liters Per Hour)

Part Number	Model	GPH Open Flow	LPH Open Flow	GPH 3' Head	LPH 3' Head	Amp Draw
4730	HD 1700	1650	6245	1260	4780	5.6
4740	HD 1700	1650	6245	1260	4780	2.8
4760	HD 2000	1850	7003	1390	5260	6.4
4770	HD 2000	1850	7003	1390	5260	3.2

The pumps can run dry for limited periods of time; however, doing so could cause pump failure.

⚠ WARNING:

To prevent personal injury, always disconnect the power source when installing or servicing any electrical product. Remove vessel from water when using any 110/120 or 220 Volt AC power tools.

DO NOT use pump to remove gasoline, oil or other flammable liquids. Doing so could result in fire, explosion, and serious personal injury.

Always use the fuse amperage rating specified for your pump model. Failure to do so could result in serious personal injury or fire hazards. Attwood bilge pumps are designed to exhaust standing WATER ONLY. They are not intended to prevent rapid accumulation of on-board water due to rough weather, severe storms, hull damage, and/or other unsafe navigational conditions.

Do not allow materials containing acetic acid (vinegar smell) such as silicone rubber sealant to contact the plastic parts of the pump. They may react with the plastic, causing cracks and pump failure.

Notice:

Discharge of oil prohibited. The Federal Water Pollution Control Act prohibits the discharge of oil or oily waste into the contiguous zone. Violators are subject to a penalty of \$5,000.

REQUIRED FOR INSTALLATION:

- Drill and suitable drill bits
- Screwdriver and four #8 stainless steel pan head screws
- Attwood thru-hull connector of appropriate size (if not already installed on boat; see chart)
- Marine sealant (Part No. 30110)
- 1-1/8" (29mm) inside diameter smooth-bore hose of suitable length
- Two appropriate hose clamps
- 16-gauge wire, brown
- 16-gauge wire, black
- Attwood 2-Way Dash-Mounted Control Switch (Part No. 7615), 3-Way Switch (Part No. 7615A)
- Fuse holder and appropriate fuse (see chart)
- Two insulated terminal connectors for 16-gauge wire
- Suitable materials to waterproof electrical connections

If automatic operation is desired:

- Attwood Automatic Float Switch, Part No. 4201 (with cover) or 4202 (with out cover) or S3 Electronic Switch, Part No. 4801 or 4802
- Additional #8 pan-head stainless steel attaching screws

The following materials are needed if no pump mounting pad is in place:

- 1/2" (1.27 cm) thick marine plywood block large enough to mount pump (and automatic float switch, if used)
- Hand-held roller
- Fiberglass—18 oz. (.5kg) mat or woven roving
- Polyester resin and catalyst

PUMP MOUNTING PREPARATION (Figure 1)

1. Choose a bilge pump mounting location in the lowest accessible part of the bilge. In this location, pump will remove the last 1" (2.54 cm) of standing water. Also, pump should be as close to the thru-hull connector as possible, for short discharge hose length.
2. To Install mounting pad on fiberglass hull: Sand gelcoat or paint off the mounting surface to create an area that is 3" (7.6 cm) wider than the mounting pad on each side.

Completely cover the mounting pad with fiberglass. Saturate the fiberglass with resin, and press the fiberglass edges down against the hull to adhere the pad in place. Roll out the fiberglass to remove any uneven surfaces, air bubbles, or excess resin.

To Install mounting pad on aluminum hull:

If your boat is not equipped with a bilge pump mounting pad we recommend that you consult your boat dealer or repair facility for instructions regarding fabrication and installation of a suitable mounting pad.

PUMP MOUNTING INSTRUCTIONS (Figure 2)

1. Determine which direction you want pump outlet fitting to point after installation. Mark pump base and mounting pad in desired position. *If Automatic Switch is to be installed, allow enough room on pad for the switch.*
2. Remove strainer basket from motor housing by depressing lock tab and twisting.
3. Screw down strainer basket with four #8 screws.
4. Attach pump to basket by pressing pump down into basket and twisting until the lock button snaps into place.

AUTOMATIC ELECTRONIC SWITCH INSTALLATION (Figure 3)

HOSE CONNECTION INSTRUCTIONS

1. If no thru-hull connector exists:

Install connector well above the water line (just under the rub rail is best) on the driver side, where water discharge can be easily monitored. Drill a hole through the hull to clear the connector threads.

Apply marine sealant around inside of nut flange (do not allow sealant to contact pump housing). Fully insert thru-hull connector, and screw nut flange down tightly. Do not over tighten.

2. Run hose from pump nozzle up to thru-hull connector, through the most direct and unobstructed path possible.
3. Before connecting hoses, cut any extra length from hose that causes downward dips or kinks in discharge line (dips can trap water and airlock the pump). Be sure the hose tension on the pump outlet is minimized to reduce stress on the pump components.
4. Place hose clamps onto hose ends. Connect ends to pump nozzle and thru-hull connector, ensuring that hoses ends fit tightly over barbs.
5. Secure both connections with hose clamps.

WIRING INSTRUCTIONS FOR AUTOMATIC OPERATION (Figure 4)

NOTE: The selected switch must have an amp rating equal to or greater than the recommended fuse. Make all wire connections above the highest possible water level, using marine grade wire connectors only. Waterproof all connections with suitable materials. **NOTE:** Failure to make waterproof connections and fuse pump properly will void the product warranty.

1. Splice suitable lengths of brown and black 16-gauge wire to exiting pump wiring, enough to reach ON/OFF/AUTO switch, automatic electronic switch, and battery.
2. Using insulated terminal connectors:
 - Connect positive lead (brown) to the ON/OFF/AUTO switch.
 - Connect negative lead (black) to negative (-) battery terminal.

In a location easily accessible for changing fuses, splice fuse holder into positive lead (brown). The fuse holder must be installed within 72" (183 cm) of the positive (+) battery terminal. Connect remaining lead from fuse holder to positive (+) terminal of the three-way switch.

3. Splice the remaining positive lead (brown) from the automatic float switch into the positive lead (brown) from the pump.
4. Connect the spliced leads to the "Manual" terminal of the three-way switch.

Important: Although the switch is submersible, the lead wires must terminate in a waterproof connection. Mount wires above the highest possible water mark to prevent electrolysis damage to the boat.

5. With three-way switch on AUTO, test electronic switch by placing a water soaked rag across the two sensors until the pump turns on (6 - 10 seconds).
6. Test pump by ensuring that pump turns on when water level is above the top sensor of the switch, and shuts off when water level is pumped down to the pump's inlet and the switch turns the pump off (approximately 60 seconds). Cycle the pump with water in the bilge several times to ensure that the system is functioning properly.

WIRING INSTRUCTIONS FOR MANUAL OPERATION (Figure 5)

1. Splice suitable lengths of brown and black 16-gauge wire to existing pump wiring, enough to reach ON/OFF switch and battery.
2. Using insulated terminal connectors, connect positive lead (brown) to the ON/OFF switch. Connect negative lead (black) to ground.
3. In a location easily accessible for changing fuses, splice fuse holder into positive lead (brown). The fuse holder must be installed within 72" (183 cm) of the positive (+) battery terminal.
4. To check system, feed water into the pump. If flow appears to be too low, make sure wires have been connected properly; brown-to-positive (switch), and black-to-negative.

CLEANING INSTRUCTIONS (Figure 6)

1. To remove the motor housing from strainer basket; depress the locking tab on basket and twist motor housing counter-clockwise.
2. Inspect impeller chamber and outlet. Remove any foreign objects.
3. Attach motor housing to pump basket by pressing pump down on base, then twist until lock button snaps into place.
4. If hair or rope get wrapped around impeller, remove chamber (see Figure 6) by rotating counter clockwise. Ensure water does not get between black plate and white motor housing. Cut tangled object off shaft. Replace chamber, tighten clockwise to ensure proper seal.

ATTWOOD HEAVY DUTY BILGE PUMP LIMITED WARRANTY:

ATTWOOD CORPORATION, 1016 North Monroe, Lowell, Michigan 49331. (Attwood') warrants to the original consumer purchaser that this Attwood Bilge Pump will be free from defects in materials and workmanship under normal use and service for:

Recreational/Pleasure Boats — A period of three (3) years from the date of original consumer purchase.

Commercial Boats — A period of one (1) year from the date of original consumer purchase.

Figure 1

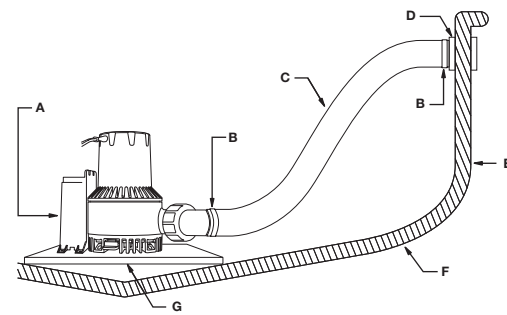

Figure 1

- A. S3 Bilge Switch
- B. Hose Clamp
- C. Hose
- D. Thru-Hull Connector
- E. Waterline
- F. Hull
- G. 1/2" (Min.) Thick Mounting Pad

Figure 2

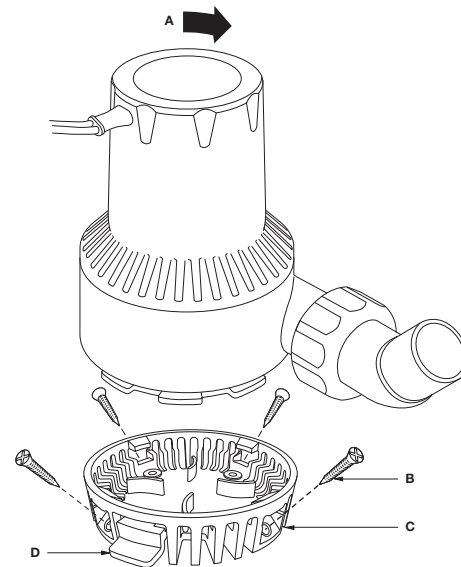

Figure 2

- A. LOCK
- B. Mounting Screws
- C. Strainer Basket
- D. Release Tab

Figure 3

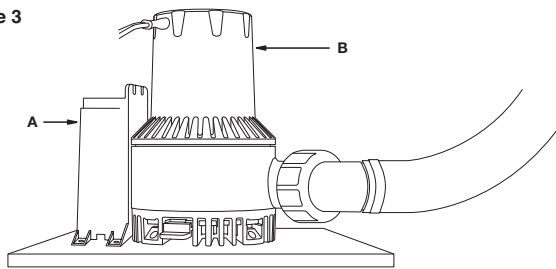

Figure 3

- A. S3 Bilge Switch
- B. Motor Housing

Figure 4

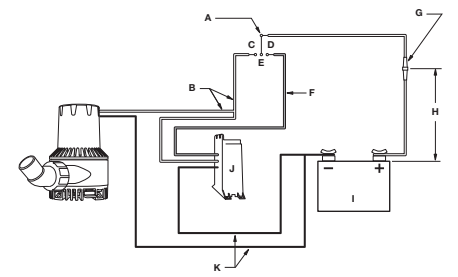

Figure 4

- A. 3-Way Switch On/Auto/Manual
- See Fuse Chart
- B. Brown Wire (+)
- C. Manual
- D. Auto
- E. Off
- F. Red Wire (+)
- G. See Fuse Chart
- H. 72" (183 mm) Maximum Length From (+) Terminal To Fuse Holder
- I. 12 Volt Battery
- J. S3 Bilge Switch
- K. Black Wire (-)

Figure 5

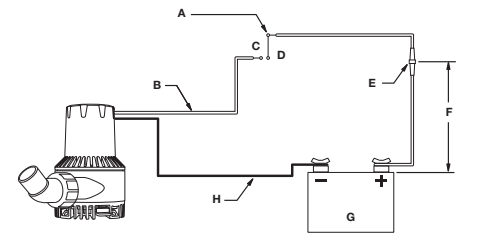

Figure 5

- A. 2-Way Switch On/Off
- B. Brown Wire (+)
- C. On
- D. Off
- E. See Fuse Chart
- F. 72" (183 mm) Maximum Length From (+) Terminal To Fuse Holder
- G. 12 Volt Battery
- H. Black Wire (-)

Figure 6

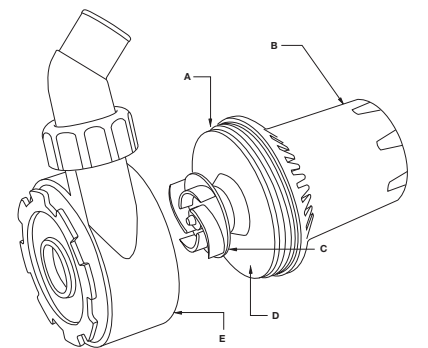

Figure 6

- A. **Note:** Motor will be loose, don't let water enter this joint
- B. Motor Housing
- C. Impeller
- D. Motor Plate
- E. Pump Chamber

Discover other boat parts & hardware on our website.